

Loop Access 2 Custom

Loop Access 2

Designed as a micro-office, meeting room, or collaboration space Access 2 features a unique zero-threshold entry and 36" wide door clearance to accommodate those with limited mobility. The durable hardwood exterior pairs perfectly with a wide range of interior colors to create a sophisticated quiet space for all.



Features

True hardwood exterior, durable laminate or felt interior, 10 mm clear tempered glass door with standard hydraulic door assist, positive pressure six fan ventilation system, overhead LED lighting with grey PET acoustic ceiling panels, occupancy sensor, drop seal door with ADA compliant handle, rigid steel subframe with floor seal gasket.

Occupancy

One to six person occupancy

Weight

1400 lbs

Specifications

Exterior Wood

Maple, Cherry, Walnut, or White Oak

Back Panel

Glass

Interior

Laminate (30 colors) or Felt (3 colors)

Accessories

Optional automatic push-button door, flip / fold seating and desk

Connectivity

Six power ports with various USB and Network configurations located in the metal subframe

Additional Customization

Frosted door glass available, custom branding available

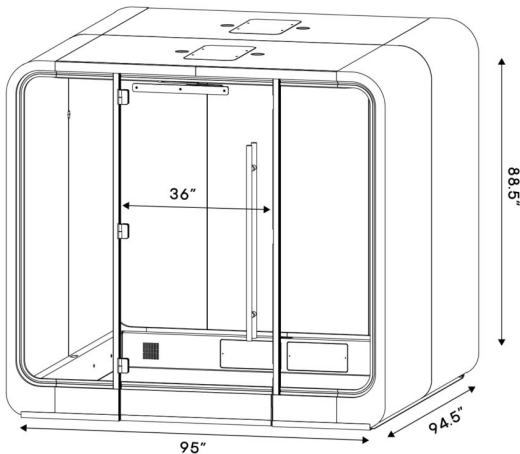

Certifications

Fully certified as conforming to UL STD 962 (Household and Commercial Furnishing) and CSA STD C22.2#203 (Modular Wiring Systems For Office Furniture). ETL Listed (Intertek 5011573). BIFMA e3 LEVEL 2 Certified for sustainable and socially responsible manufacturing. For detailed product information, please reference the Technical Information Sheet.



Measurements

Booth

H 88.5" / W 95" / L 94.5"

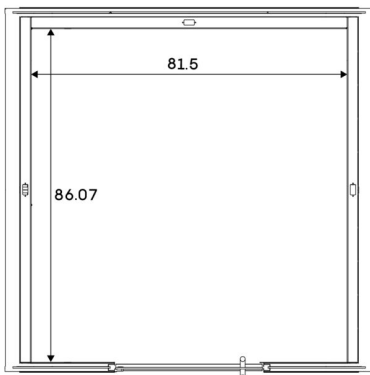

Loop Access 2 Custom

Technical Information

The Loop Access 2 Custom is ADA 2010 compliant with a 304.3.2 T shaped turning space, zero entry / exit threshold design, and optional fold up table and seats to provide privacy for those with mobility issues. The pod is a “plug and play” meeting booth proudly designed and manufactured in Canada. The product delivers in three main sections from our factory in Edmonton and is easily assembled on site in under three hours. The finishes and specifications for the Loop Access 2 Custom have been hand selected for quality, safety, durability, and sustainability.

- 1. Occupancy:** One to six person occupancy
- 2. Exterior Dimensions:** Front 94.5” (2350 mm) x Depth 95” (2400 mm) x Height 88.5” (2223 mm). For detailed dimensions of interior and exterior, please refer to “Loop Access 2 Custom Product Spec Sheet.”
- 3. Weight:** 1400 lbs.
- 4. Standards:** Tested and certified for stability and mechanical strength, safety in use, fire ratings, and electrical in accordance to UL STD 962 (Housing and Commercial Furnishings) and CSA STD C22.2#203 (Modular Wiring Systems for Office Furniture). ETL listed through Intertek (#5011573). BIFMA e3 LEVEL 2 Certified for sustainable and socially responsible manufacturing. All glass has been tempered to ANSI Z97.1.
- 5. Acoustic Performance:** NIC rating of 26 as achieved through testing in accordance to ASTM E336 “Standard Test Method for Measurement of Airborne Sound Attenuation Between Rooms in Buildings.” Acoustic absorption material (NRC rating of 23) covers 100% of the ceiling (excluding lights and fan areas). STC rating of 34 for 10 mm monolithic glass door.
- 6. Ventilation:** Fully integrated six active fan ventilation system to achieve 30 air changes per hour (each fan rated to 22.4 l/s). Makeup air opening in ceiling and at floor level as part of ventilation system. Ventilation system features acoustic sound baffles to reduce sound transmission while ensuring proper airflow. Fan speed is preprogrammed for optimal performance. 22 dBA NC.
- 7. Lighting:** Four flush mounted, energy efficient LED light panels integrated into the acoustic ceiling panel. Lighting produces 325 LUX illumination.
- 8. Electrical:** All electrical has been tested and is certified to UL 962 and CSA C22.2. Lighting and fans are controlled by a preprogrammed occupancy sensor for automatic shutoff after 30 minutes of inactivity for optimal product performance. All serviceable electrical components feature quick connectors for ease of ongoing maintenance. All power outlets and electrical components are hardwired into the booth. Amperage and voltage is 15A 120V. The booth comes included with a 6’ power cord that exits the back of the booth and is designed to be plugged into a standard 15A wall receptacle. The booth comes standard with six power and six USB ports integrated into the lower structure. Optional network and other electrical configurations available upon request.
- 9. Furniture:** Fold up cantilever work surface is integrated and attached to the interior back wall of the pod and designed to accommodate and support a laptop. Position of work surface relative to the seats is designed to accommodate the 5th to 95th percentile based on universal principles of design. Two facing seats and backrests are fully integrated and attached to the interior walls of the pod. Seats fold up to allow for accessibility for those with mobility issues. Width of seats and dimensions are designed to accommodate two occupants per seat comfortably. Upholstered components of seat are individually removable for easy repair and maintenance. For detailed dimensions of work surface and seat, please refer to “Loop Access 2 Custom Product Spec Sheet.” Custom bench seating, lounge seating, and / or integrated desk available upon request.
- 10. Door:** 10 mm thick monolithic glass door with right-hand out swing door pivot. Doors seal with active magnetic door closure against dual fin EPDM foam gasket. Dual fins create an acoustic air pocket between the door glass and the foam seal. Door clearance of 36” at midpoint with hydraulic door assist. Optional integrated automatic accessible door mechanism with push button to open. Zero threshold for entry and egress for those with reduced mobility.
- 11. Finishes:** Exterior of booth is composed of a hardwood veneer sheeting. Ceiling and interior walls of the booth are sheeted with durable high pressure laminate or felt available in a variety of different color options. Back panel is tempered safety glass.
- 12. Fire Protection:** All finishes are non-flammable. Exterior is finished in water based sealer with Class A flame spread rating. Upholstery and foam meet California Bulletin #117-2013. Sprinkler knockout included for optional installation by a trained professional (based on jurisdictional requirements). Optional certified and fully integrated self-contained sprinkler that does not require plumbing into building available upon request.
- 13. Environmental:** Exterior water based finish meets criteria for Greenguard, interior high pressure laminate Greenguard Gold Certified, interior upholstery Greenguard Gold Certified, Acoustic insulation Greenguard Certified, all construction and finishing plywood CARB Compliant. BIFMA e3 LEVEL 2 Certified for sustainable and socially responsible manufacturing. Third party tested for VOC emissions and compliant with ANSI/BIFMA X7.1-2001(R2021) and ANSI/BIFMA e3-2014e Section 7.6.1. Recognized by USGBC LEED Version 4/4.1, ID&C Standards, the WELL Building Standard, WELL v2, Feature X06, and BIFMA Level certification.