

# Loop Solo QS



## Loop Solo QS

The Loop Solo QS offers a simple, elegant, flexible solution to distractions and noise in open concept offices. With the same great form and function as our Loop Solo, our QS model features an all white exterior with a soft grey interior. Neutral finishes and a minimalist color palette makes QS ideal for any interior environment.

### Features

Durable white laminate exterior, grey felt interior, minimalist light grey cloth upholstery, 10 mm clear tempered glass, positive pressure two fan ventilation system, overhead LED light, occupancy sensor, concealed magnetic door closure, high quality upholstered seat with ergonomic backrest and work desk. Delivers fully assembled with power cord for plug-and-play install.

### Occupancy

One person occupancy

### Weight

550 lbs

### Specifications

#### Exterior Laminate

White laminate

#### Back Panel

Light grey PET felt

#### Interior

Light grey PET felt ceiling with color matched grey laminate

#### Seat Upholstery

Minimalist light grey cloth

#### Connectivity

One power port and two USB ports located in the desk

### Certifications

Fully certified as conforming to UL STD 962 (Household and Commercial Furnishing) and CSA STD C22.2#203 (Modular Wiring Systems For Office Furniture). ETL Listed (Intertek 5011573). BIFMA e3 LEVEL 2 Certified for sustainable and socially responsible manufacturing. For detailed product information, please reference the Technical Information Sheet.

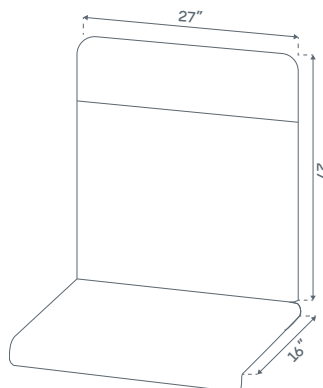
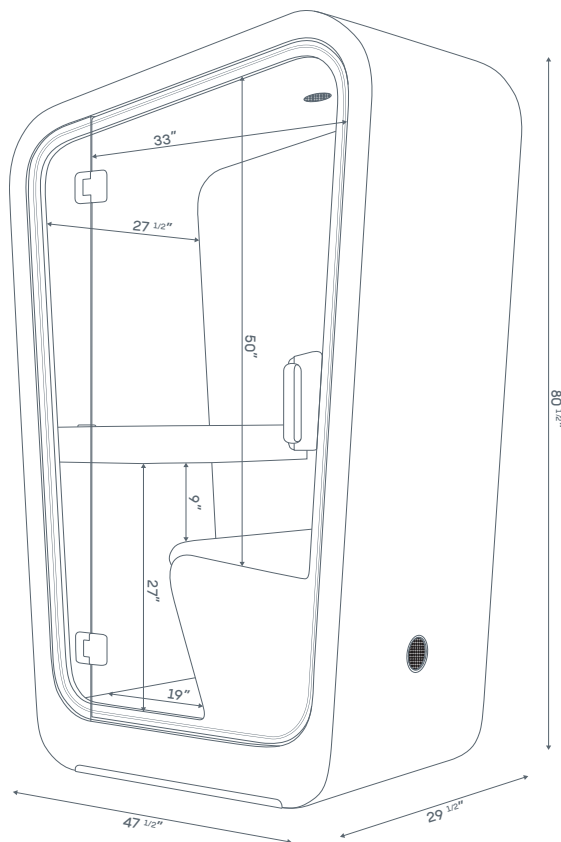

### Measurements

#### Booth

H 80.5" / W 47.5" / L 29.5"

#### Desk

H 4" / W 14.5" / L 27.25"

#### Seat

H 27" / W 27" / L 16"

## Technical Information

The Loop Solo QS is a “plug and play” telephone booth proudly designed and manufactured in Canada. The product delivers fully assembled from our factory in Edmonton. The finishes and specifications for the Loop Solo QS have been hand selected for quality, safety, durability, and sustainability.

- 1. Occupancy:** Single person occupancy.
- 2. Exterior Dimensions:** Front 47.5” (1207 mm) x Depth 29.5” (749 mm) x Height 80.5” (2045 mm). For detailed dimensions of interior and exterior, please refer to “Loop Solo QS Product Spec Sheet.”
- 3. Weight:** 550 lbs.
- 4. Standards:** Tested and certified for stability and mechanical strength, safety in use, fire ratings, and electrical in accordance to UL STD 962 (Housing and Commercial Furnishings) and CSA STD C22.2#203 (Modular Wiring Systems for Office Furniture). ETL listed through Intertek (#5011573). BIFMA e3 LEVEL 2 Certified for sustainable and socially responsible manufacturing. All glass has been tempered to ANSI Z97.1.
- 5. Acoustic Performance:** NIC rating of 31 as achieved through accredited third party testing in accordance to ASTM E596 “Standard Test Method for Measurement of Noise Reduction of Sound-Isolating Enclosures.” Acoustic absorption material (NRC rating of 23) covers 100% of the ceiling (excluding lights and fan areas). STC rating of 34 for 10 mm monolithic glass door.
- 6. Ventilation:** Fully integrated two active fan ventilation system to achieve 54 air changes per hour (each fan rated to 22.4 l/s). Makeup air opening in ceiling and at floor level as part of ventilation system. Ventilation system features acoustic sound baffles to reduce sound transmission while ensuring proper airflow. Fan speed is preprogrammed for optimal performance. 20 dBA NC.
- 7. Lighting:** Flush mounted, energy efficient gimble LED light mounted in the ceiling with angle / tilt adjustment for user preference. Lighting produces 353 LUX illumination.
- 8. Electrical:** All electrical has been tested and is certified to UL 962 and CSA C22.2. Lighting and fans are controlled by a preprogrammed occupancy sensor for automatic shutoff after 30 minutes of inactivity for optimal product performance. All serviceable electrical components feature quick connectors for ease of ongoing maintenance. All power outlets and electrical components are hardwired into the booth. Amperage and voltage is 7A 120V. The booth comes included with a 6’ power cord that exits the back of the booth and is designed to be plugged into a standard 15A wall receptacle. The booth comes standard with one 5-15R spill proof power receptacle hardwired and located in the desk. Option for two hardwired and fully integrated USB ports and network / data ports available upon request.
- 9. Furniture:** Work surface is integrated and attached to the interior wall of the pod and designed to accommodate and support a laptop. Position of work surface relative to the seat is designed to accommodate the 5th to 95th percentile based on universal principles of design. Seat and backrest is fully integrated and attached to the interior wall of the pod. Width of seat and dimensions are designed to accommodate one occupant comfortably. Upholstered components of seat are individually removable for easy repair and maintenance.
- 10. Door:** 10 mm thick monolithic glass door with right-hand out swing door pivot. Door seals with active magnetic door closure against dual fin EPDM foam gasket. Dual fins create an acoustic air pocket between the door glass and the foam seal. Door clearance of approximately 30” at midpoint. Door opens with one releasing operation by pulling on door handle to disengage the magnetic door latch.
- 11. Finishes:** Exterior of booth is composed of a durable high pressure white laminate. Standard seat finish is a durable neutral grey woven upholstery (100,000 double rubs). Other seat upholstery options are available upon request. Ceiling, interior walls, and interior back panel of the booth are sheeted in a neutral grey PET acoustic felt. Work surface, under desk panel, under seat panel, and floor are sheeted in a neutral grey high pressure laminate.
- 12. Fire Protection:** All finishes are non-flammable. Class A flame spread rating for acoustic felt interior and wall lining. Upholstery and foam meet California Bulletin #117-2013. Sprinkler knockout not required as per size and dimensions of booth.
- 13. Environmental:** Interior and exterior high pressure laminate Greenguard Gold Certified, interior upholstery Greenguard Gold Certified, Acoustic insulation Greenguard Certified, all construction and finishing plywood CARB Compliant. BIFMA e3 LEVEL 2 Certified for sustainable and socially responsible manufacturing. Third party tested for VOC emissions and compliant with ANSI/BIFMA X7.1-20011(R2021) and ANSI/BIFMA e3-2014e Section 7.6.1. Recognized by USGBC LEED Version 4.4.1, ID&C Standards, the WELL Building Standard, WELL v2, Feature X06, and BIFMA Level certification.